

THE PIX-II EXPERIMENT: AN OVERVIEW

Carolyn K. Purvis
National Aeronautics and Space Administration
Lewis Research Center
Cleveland, Ohio 44135

The second Plasma Interactions Experiment (PIX-II) was launched in January 1983 as a piggyback on the second stage of the Delta launch vehicle that carried IRAS into orbit. Placed in a 870-km circular polar orbit, it returned 18 hr of data on the plasma current collection and arcing behavior of solar array segments biased to ± 1000 V in steps. The four 500-cm² solar array segments were biased singly and in combinations. In addition to the array segments PIX-II carried a sun sensor, a Langmuir probe to measure electron currents, and a hot-wire filament electron emitter to control vehicle potential during positive array bias sequences. Like its predecessor, PIX-I, PIX-II was designed, built, and tested at the NASA Lewis Research Center. This paper provides an overview of the PIX-II experiment from program and operational perspectives.

INTRODUCTION

Most U.S. spacecraft to date have used low-voltage solar arrays, generating power at ~ 30 V. The highest voltage array flown by NASA was on Skylab, which had an array voltage of 70 to 115 V and generated 16 kW of power. Space stations and other large future systems will require increasing power generation capability. As power levels increase, the weight and I^2R power loss penalties for maintaining low solar array voltages increase dramatically (refs. 1 to 3). Power systems generating hundreds of kilowatts are required for such missions as the space station. At these power levels, voltages of at least a few hundred volts are required to reduce internal resistive losses within the array and to reduce the wiring harness mass required to transport the power. This need to operate at higher voltages has spurred evaluation of high-voltage solar array operation in space.

Solar array systems consist of strings of solar cells with metallic interconnects between them. These interconnects are at voltages that depend on their positions in the array circuit and are usually exposed to the environment. When these systems are placed in orbit, they will interact with the naturally occurring space plasma. Two types of potentially hazardous interactions to an isolated solar array in orbit are presently recognized: power loss from parasitic currents through the plasma, and arcing. Both of these interactions are plasma density dependent and present greater hazards at higher densities. The low temperature ionospheric plasma has a peak density (of $\sim 10^6$ particles/cm³) at about 300-km altitude (ref. 4). High-voltage system - plasma interactions will therefore be most severe in low Earth orbits.

The PIX-II experiment was conducted to provide flight data on high-voltage solar array - plasma interactions. These data are being analyzed to calibrate ground simulation results and to guide and validate modeling efforts. This paper presents the background, describes the experiment, and summarizes the

operational sequences that characterize the data set. The following papers describe some results of the data analysis.

BACKGROUND

Investigation of interactions between high-voltage systems and thermal plasmas was begun in the late 1960's. Experimental work using small segments of solar arrays and insulated electrodes with pinholes indicated that the presence of the insulators caused plasma current collection phenomena that departed dramatically from the predictions of Langmuir probe theory. Experiments indicated greatly enhanced electron collection at voltages in excess of about +150 V and arcing on solar array segments biased several hundred volts negative with respect to plasma ground. Concern for the implications of these results for high-voltage systems in orbit prompted the development of the SPHINX (Space Plasma High Voltage Interactions Experiment) satellite (ref. 5). SPHINX was launched in early 1974 but failed to attain orbit due to a launch vehicle malfunction.

After the loss of SPHINX, the attention of the environmental interactions community was for several years focused on investigating spacecraft charging, an interaction that had been found to be hazardous for geosynchronous spacecraft and was intensively studied by NASA and the Air Force. In the late 1970's, interest in high-voltage interactions again intensified, and their study was resumed under the auspices of the joint NASA/USAF Environmental Interactions Technology Investigation (ref. 6). The ground technology program utilizes the experimental facilities at NASA and USAF centers and builds on the modeling capabilities developed during the spacecraft charging investigation, as well as using the earlier high-voltage-study results (refs. 7 to 12). The goal is to develop guidelines and analytical tools to guide the design of large high-voltage systems in Earth orbit. The approach is to perform experiments and develop models in an interactive program in which experimental results are used both to guide and validate the models.

The ground technology programs require complementary flight experiment data to calibrate the ground-based testing, to guide and validate the models, and to investigate experimental conditions not obtainable in ground facilities. The first such data were obtained by the Plasma Interaction Experiment-I (PIX-I) which flew in March 1978 as a piggyback on a second-stage Delta launch vehicle. It remained with the Delta stage, operating in a 900-km circular near-polar orbit for 4 hr. About 2 hr of data were returned by real-time telemetry. The mission time was limited by the lifetime of the second-stage Delta's telemetry battery; data return was limited by the real-time recovery requirement. The PIX-I results verified that the electron collection enhancement and arcing phenomena observed in ground tests also occur in space (ref. 13).

THE PIX-II EXPERIMENT

Objectives and Approach

The basic objectives of the PIX-II experiment were to acquire flight data for use in calibrating the ground simulation facilities and in developing and validating models. Because the orbital environment cannot be duplicated on the ground, flight data are required to evaluate the effect of simulation inadequacies on the plasma collection and arcing response of solar arrays. Of

particular concern for PIX-II were the current collection and arc threshold behavior of array segments in proximity to one another.

The approach chosen was to divide the experimental array into four independently biasable segments, each of area about 500 cm². These were biased in a preprogrammed sequence in various combinations, in voltage steps to ± 1000 V. Currents collected by each of the array segments were measured by electrometers. A hot wire filament electron emitter was included to avoid large negative potential excursions of the vehicle during high positive bias conditions on the arrays. A spherical Langmuir probe and a sun sensor were included to provide plasma diagnostic and orientation information. The package was designed as a piggyback experiment to remain with the second stage of a Delta launch vehicle.

Experiment System

The PIX-II experiment was designed and built at Lewis. The design was based on that of PIX-I, with a number of changes incorporated to improve the quality and quantity of data obtained.

PIX-II consisted of two major subassemblies: the electronics enclosure box and the experiment plate. These were located 180° from each other around the Delta's circumference (fig. 1).

The experiment plate (fig. 2) was 91.4 cm (36 in) in diameter, truncated to 81.3 cm (32 in) at the top to fit the launch vehicle. The four-segment solar array, 48.3 by 40.6 cm (19 by 16 in), was located on the front center of the plate. The 134° acceptance angle sun sensor was located 5.7 cm (2.25 in) above the solar array and 7.0 cm (2.75 in) to the left of center.

For thermal control the space-facing side of the experiment plate, except for the arrays, was covered with a single layer of 2.5×10^{-3} cm (1 mil) aluminumized Kapton coated with a black conductive paint (Sheldahl G113600), black side out. This sheet was attached to the plate with Kapton tape and stainless steel screws, the latter providing electrical grounding for the black coating.

The solar cells used on the PIX-II program were flight-qualified cells identical to those used on other flight programs. The cells were 2- by 2-cm silicon solar cells 0.03 cm (0.012 in) thick with a bulk resistivity of 10 ohm-cm. The coverslides were type 7940 silica 0.05 cm (0.020 in) thick. The cells were configured in segments, each consisting of 19 series-connected submodules. Each submodule consisted of six parallel-connected solar cells. There were 114 solar cells per segment, so the total number of cells flown was 456. For comparison, 24 cells were flown on PIX-I. The peak power capability of the solar panel was 25 W, but no power was drawn from the cells since each segment was shorted from one end to the other.

Each segment was mounted on a fiberglass sheet. All four segments were bonded with polyurethane adhesive to a 0.013-cm (5-mil) thick, 40.6- by 53.3-cm (16- by 21-in) Kapton sheet to achieve good electrical isolation. The Kapton sheet was bonded with polyurethane adhesive to a 0.95-cm (0.375-in) thick aluminum substrate of the same dimensions as the sheet. This assembly was bolted to the experiment plate.

The sun sensor, used to indicate the test array orientation relative to the sun was a vertical multijunction solar cell. It worked into a fixed resistor to provide a 0- to 4-V signal whenever the Sun was within its 134° field of view. Its location on the experiment plate is shown in figure 2.

The electronics enclosure box (fig. 3) was a rectangular structure 58.4 by 54.6 by 30.5 cm (23 by 21.5 by 12 in). It housed the experiment electronics and battery and supported the deployable Langmuir probe and the hot-wire filament electron emitter probe. The outside surfaces of the box were covered with a multilayer insulation (MLI) blanket of 0.00254 cm (1 mil) aluminized Kapton. The outer-facing layer was 0.00254 cm (1-mil) aluminized Kapton covered with an electrically conductive black coating of Sheldahl G113600, black side out. The MLI blanket and black coating were electrically grounded with straps connected to the structure.

The interior of the enclosure box consisted of three stiffened trays of shelves to which the various electronics boxes and the experiment battery were attached.

The high-voltage power supply provided a programmable voltage to the PIX-II solar array experiments via the electrometer package. It was programmable to provide 32 voltage steps from 0 to 1 kV. It accepted 24 to 32 V dc input to a maximum power of 110 W and outputted 0- to 1-kV positive voltages at 80-mA maximum current and 0- to 1-kV negative voltages at 4-mA maximum current.

The PIX-II electrometer provided four independent channels, one for each array segment. The electrometer floated at the high-voltage supply potential and measured electron currents in the range 1 μ A to 80 mA (positive voltages) and ion currents of 0.01 μ A to 1.0 mA (negative voltages). In addition to measuring collected plasma currents, the electrometer box incorporated the high-voltage-array switching function.

The experiment command sequencer and data multiplexer unit (SEQ/MULT) controlled the operational configuration of the experiment while collecting and compiling data from the remaining electronics subsystems. The command sequencer was a read-only-memory-based controller that was preprogrammed to the desired flight sequence before launch. After executing the preprogrammed sequence (8 hr, 53 min, 20 s after turnon), the sequencer cycled to the start and repeated it. The data multiplexer collected and compiled experiment information and formatted it into a serial stream for use by the Delta transmitter. The SEQ/MULT box also housed the data storage unit, a solid-state memory that was included to ensure full-orbit data coverage.

The power control unit (PCU) provided power conditioning, control, and distribution for PIX-II and interfaced to the Delta. It served as the single-point ground reference for the experiment and provided power returns to each component. The PCU box also housed the electronics associated with the hot-filament emitter.

The battery provided power to the entire flight experiment. It contained 18 silver-zinc cells rated at 15-Ah capacity in a sealed case.

The Langmuir electronics unit operated the Langmuir probe to provide a measurement of plasma density. The probe voltage could vary from -20 to

+110 V in steps, and currents in the range 10^{-8} to 10^{-4} A could be recorded. The probe voltage stepped through its range (in 5- and 10-V steps) during probe sweeps. When not sweeping, the probe voltage was held at +50 V. The Langmuir probe was located on one side of the electronics enclosure box (figs. 1 and 3). It was stowed during launch and deployed 90° to the side of the box after the Delta's depletion burn. Overall length of the assembly was 71.1 cm (28 in). The probe itself was a 1.9-cm (3/4-in) diameter aluminum sphere.

Like the Langmuir probe the hot-filament emitter was attached to the electronics box and deployable by using an identical release mechanism. It deployed 90° from the face of the electronics box (approximately radially outward from the Delta vehicle). The filament's purpose was to emit electrons to neutralize the charge collected when the solar arrays were at high positive bias in order to minimize charging of the Delta vehicle under these conditions.

The flight hardware underwent thermal-vacuum, vibration, shock, and plasma testing and a functional electrical checkout before launch.

The Flight

PIX-II was launched with IRAS on Delta launch 166 on January 25, 1983, at 9:17 p.m. e.s.t. (01-26-83, 03:17 G.m.t.). PIX-II was activated at 03:28:20 G.m.t. on January 26, after release of IRAS. Its orbit was 870 km circular, 100° inclination. PIX-II was near the terminator and experienced eclipse conditions for about 8 min per 103-min orbit, near the north pole. Experiment duration was limited by the lifetime of the Delta telemetry battery and the experiment battery. Design life was 10 hr. In fact, PIX-II returned about 18 hr of data as both real-time data and memory dumps. The experiment operated nominally except that full deployment of the Langmuir probe was uncertain. The probe was released from its stowed position, but the signal indicating latching into the fully deployed position was not received. The attitude of the Delta vehicle was variable since there was no active attitude control.

Data Obtained

Figure 4 summarizes the PIX-II experimental arrangement from the "science" point of view. The four array segments were biased independently in various combinations to ± 1 kV in steps and the collected currents measured in a pre-programmed sequence. Langmuir probe sweeps were done periodically as part of the sequence. The emitter was activated during most positive-voltage scans, although some were done with the emitter off to evaluate its effectiveness. Electron currents of 10^{-7} to 10^{-2} A (positive voltages) and ion currents of 10^{-8} to 10^{-3} A (negative voltages) were recorded.

The voltage bias levels used were 0, ± 30 , ± 60 , ± 95 , ± 125 , ± 190 , ± 250 , ± 350 , ± 500 , ± 700 , and ± 1000 V. These were stepped through sequentially (e.g., 0, +30, +60, etc.). Each voltage was held for 16 s for most voltage scans, although a few used 32-s steps. Currents in each electrometer were read at 2-s intervals.

Table I summarizes the array bias scans and Langmuir probe operations conducted during one full program sequence, over a period of 8 hr 53 min 20 s. Two full program sequences and one partial sequence were completed during the flight. For clarity of presentation the array segments have been numbered 1

to 4, from left to right in the view depicted in figure 2. The first column identifies which segments were being biased. Segments not biased in a given scan were electrically floating. Thus an entry of "1" signifies array segment 1 biased and segments 2, 3, and 4 floating; an entry of "1 + 4" signifies segments 1 and 4 biased and segments 2 and 3 floating, and so forth. The entry "Gradient" refers to a special mode in which a constant 100-V bias difference was maintained between adjacent array segments during a scan. In this case $V_1 > V_2 > V_3 > V_4$ and $V_i - V_j = 100$ V, $(i,j) = (1,2)$ or $(2,3)$ or $(3,4)$, where the subscripts refer to segment numbers. All four arrays were biased in the gradient mode. The number of scans during which the hot-wire-filament emitter was activated is a subset of the total number of positive scans, so a table entry of "12 (10)" signifies 12 positive bias scans of which 10 were done with the emitter on.

Langmuir probe scans were done during the sequence at 1/2- and 1-hr intervals, for a total of 11 scans in the full sequence. During scans the voltage was stepped from -20 V to +20 V in 5-V increments and then from +20 V to +110 V in 10-V increments. Each voltage up to 50 V was held for 4 s; the 60-V level was held for 1 s; and the remaining voltages for 2 s each. Current was measured at 1-s intervals. The array segments were held at 0 V during most probe scans, and at 30 V for a few. When the probe was not scanning, it was held at +50 V and its current was monitored at 2-s intervals.

At high negative voltages arcing of the array segments was anticipated. In view of this the high-voltage power supply was shut off when an "overload" current of 1 mA of ions was reached. The original design intended the power supply to recycle back to voltage in 2 s. Last-minute addition of a capacitor resulted in the system's being unable to recycle properly at high negative voltages. Thus, when an arc resulted in shutdown of the power supply, the supply generally could not recycle until the beginning of the next voltage scan. For example, if an arc resulted in shutdown at -500 V in a given scan, no data were obtained at -700 or -1000 V for that scan. This has resulted in some loss of data for the negative-voltage scans.

Data Analysis

Results of data analysis activities to date are summarized in papers by Grier (ref. 14), Ferguson (ref. 15), and Roche and Mandell (ref. 16). Interpretation of the data has been complicated by the variable and uncertain Delta attitude, and by ram/wake effects, which make it difficult to assess local plasma conditions on the array.

Data analysis efforts to date have focused on laboratory-flight comparisons (ref. 14) and ram/wake effects (ref. 15). Findings include evidence for a tank wall effect in ground testing; less effect from emitter operation in space than on the ground; lower than expected arc threshold voltages; confirmation that arc threshold depends on plasma density; and the strong influence of ram/wake effects.

Comparing the flight data with predictions of the NASCAP/LEO code (ref. 16) indicated a need for code refinements. Efforts to analyze and interpret the PIX-II data and to compare them with ground test results and model predictions are continuing.

SUMMARY

The PIX-II experiment was conducted to provide flight data on the interactions between high-voltage solar arrays and space plasmas. Understanding these interactions is critical to the design of high-voltage photovoltaic power systems for low-Earth-orbit applications. Flight data are required to calibrate ground simulations and to guide and validate interaction modeling efforts. The PIX-I experiment flown in 1978 returned data that established that the current collection and arcing phenomena observed in ground tests do occur in orbit. Like its predecessor, PIX-II was designed, built, and tested at the NASA Lewis Research Center and flown as a piggyback on a second-stage Delta. The data set recovered is far more extensive than that from PIX-I (18 hr of data with full orbit coverage as compared with 1 hr of real-time data) and focused on the crucial solar array interactions. Analysis and interpretation of the data have been complicated by the lack of well-defined attitude information and the influence of ram/wake effects. Several significant results have been obtained. These include evidence for lower arc thresholds in space than are observed on the ground; confirmation of the arc threshold voltage dependence on plasma density; and evidence for tank wall effects at high positive voltages. Much remains to be done to evaluate fully the information contained in the data base that PIX-II's successful flight has provided. Data analysis and interpretation are continuing along several lines.

REFERENCES

1. Stevens, N.J.: Interactions Between Spacecraft and the Charged-Particle Environment. Spacecraft Charging Technology - 1978, NASA CP-2071, 1979, p. 268.
2. Finke, R.C.; Myers, I.T.; Terdan, F.F.; and Stevens, N.J.: Power Management and Control for Space Systems. Future Orbital Power Systems Technology Requirements, NASA CP-2058, 1978, p. 195.
3. Renz, D., et al.: Design Considerations for Large Space Electric Power Systems. NASA TM-83064, 1983.
4. Smith, R.E.; and West, G.C., compilers: Space and Planetary Environment Criteria Guidelines for Use in Space Vehicle Development, 1982 Revision (Vol. 1), NASA TM-82478, 1983.
5. Stevens, N.J.: Solar Array Experiments on the SPHINX Satellite. NASA TM X-71458, 1973.
6. Pike, C.P.; and Stevens, N.J.: Agreement for NASA/OAST-USAF/AFSC Space Interdependency on Spacecraft-Environment Interaction. Spacecraft Charging Technology - 1980, NASA CP-2182, 1981, p. 912.
7. Kennerud, K.L.: High Voltage Solar Array Experiments. NASA CR-121280, 1974.
8. McCoy, J.E.; and Konradl, A.: Sheath Effects Observed on a 10-Meter-High Voltage Panel in Simulated Low Earth Orbit Plasmas. Spacecraft Charging Technology - 1978, NASA CP-2071, 1979, p. 315.

9. McCoy, J.E.; and Matucci, D.T.: Experimental Plasma Leakage Currents to Insulated and Uninsulated 10 m² High-Voltage Panels. Spacecraft Charging Technology - 1980, NASA CP-2182, 1981, p. 931.
10. Katz, I.; et al.: Additional Application of the NASCAP Code. NASA CR-165349, 1981.
11. Nonnast, J.H.; et al.: Numerical Simulation of Plasma-Insulator Interactions in Space, Part I: The Self-Consistent Calculation. Spacecraft Charging Technology - 1980, NASA CP-2182, 1981, p. 932.
12. Chaky, R.C.; et al.: Numerical Simulation of Plasma-Insulator Interactions in Space, Part II: Dielectric Effects. Spacecraft Charging Technology - 1980, NASA CP-2182, 1981, p. 946.
13. Grier, N.T.; and Stevens, N.J.: Plasma Interaction Experiment (PIX) Flight Results. Spacecraft Charging Technology - 1978, NASA CP-2071, 1979, p. 295.
14. Grier, N.T.: Plasma Interaction Experiment II (PIX-II): Laboratory and Flight Results. This volume.
15. Ferguson, D.C.: Ram/Wake Effects on Plasma Current Collection of the PIX-II Langmuir Probe. This volume.
16. Roche, J.C.; and Mandell, M.J.: NASCAP Simulation of PIX-II Experiments. This volume.

TABLE I. - PIX-II EXPERIMENT

[One full program sequence.]

(a) Array bias scans (0 to ± 1000 V)

Segment	Number of positive voltage scans ^a	Number of negative voltage scans
1	12 (10)	8
2	↓	9
2+3		8
1+4		9
1+2+3		8
1+2+3+4		10
Gradient	3 (3)	3

(b) Langmuir probe scans

- -20 to +110 V (11 per sequence)
- Held at +50 V when not scanning

^aNumber in parentheses denotes number of scans during which hot-wire-filament emitter was activated.

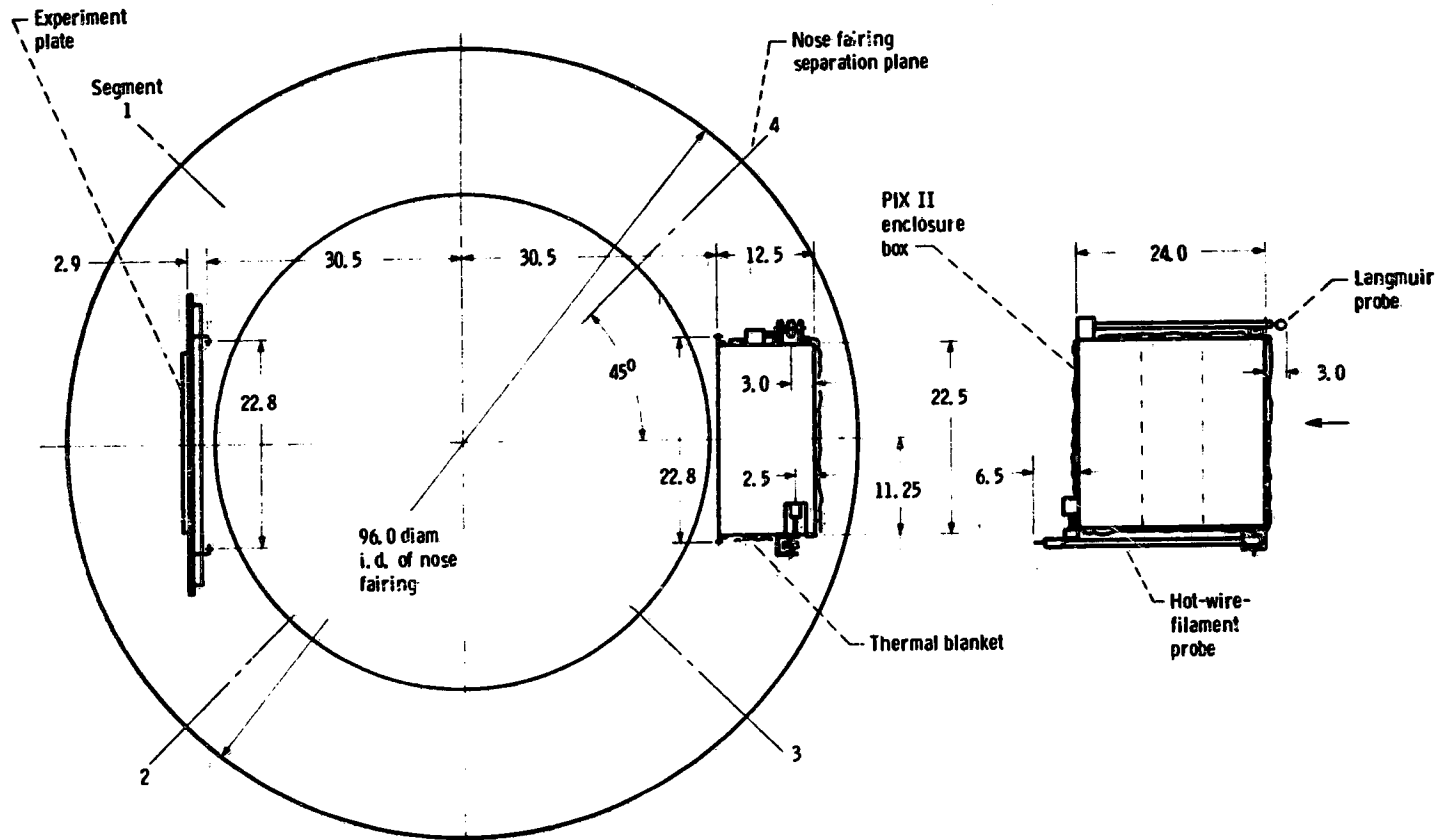

Figure 1. - PIX II/Delta. (Dimensions are in inches.)

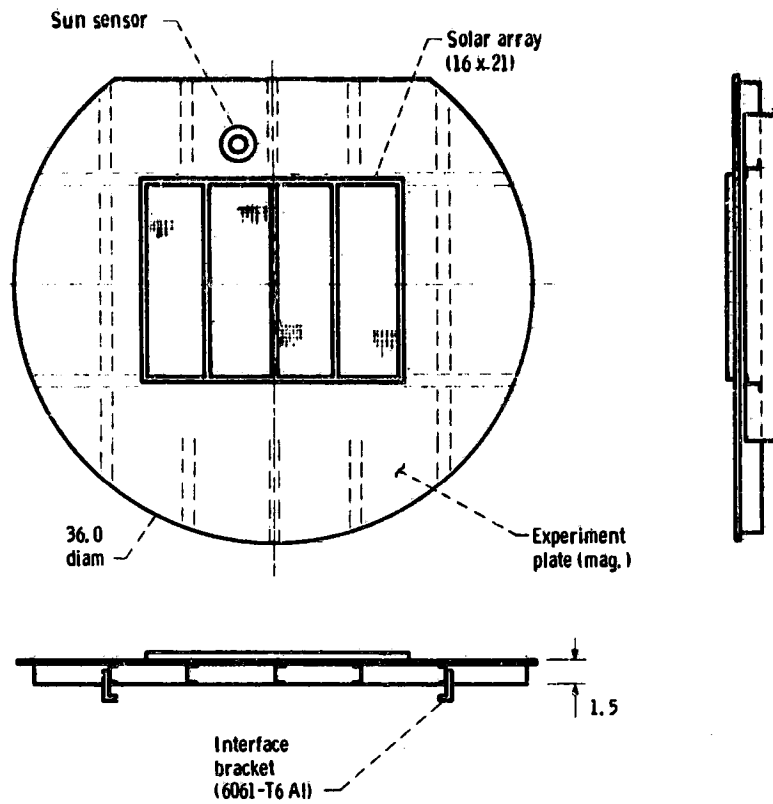

Figure 2. - Experiment plate assembly. (Dimensions are in inches.)

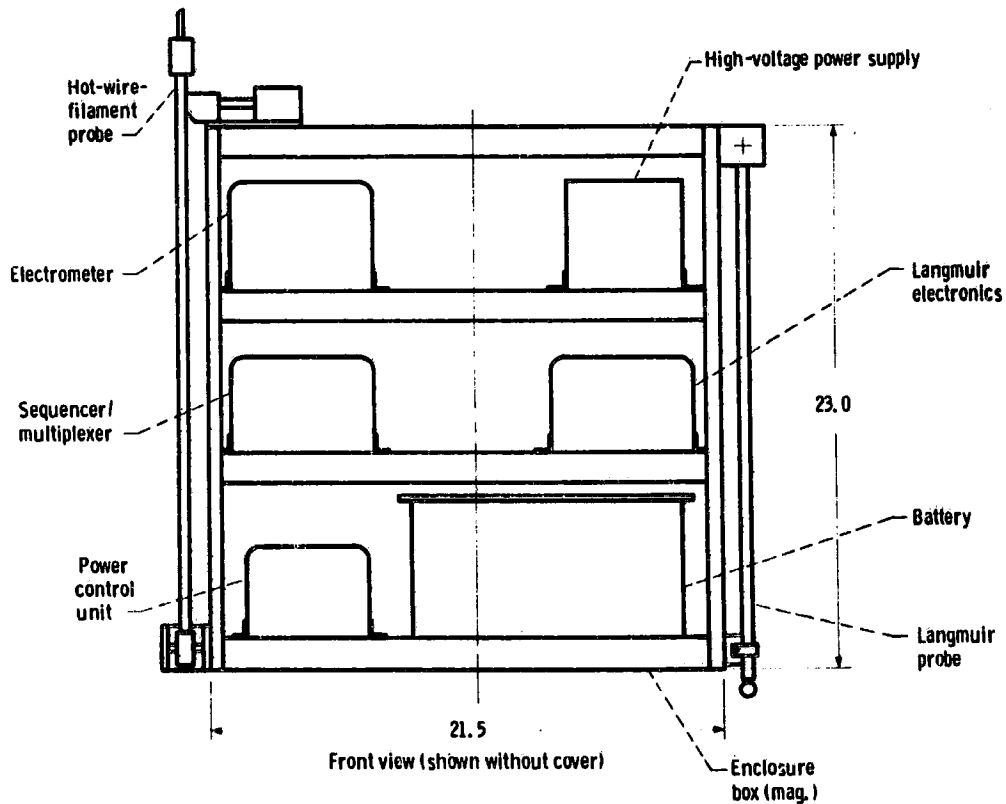

Figure 3. - Enclosure box assembly. (Dimensions are in inches.)

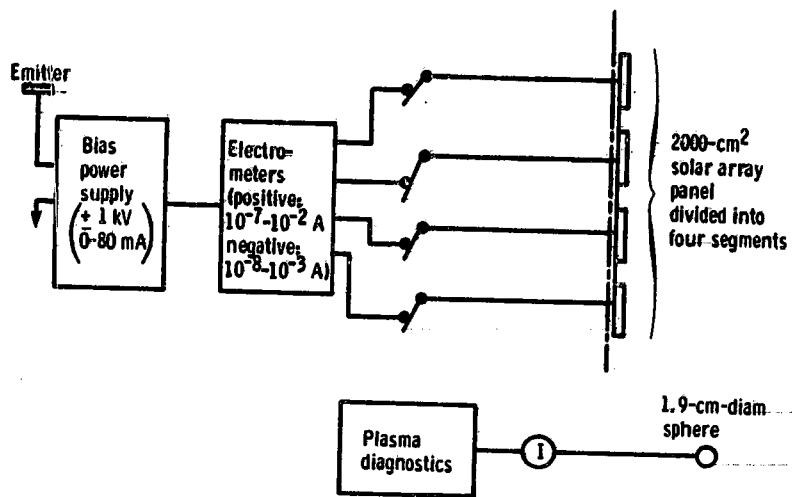

Figure 4 - PIX II electrical arrangement.